

**Date of Issue:** August 2022 (*Monogram Program Effective Date: February 2023*)

**Affected Publication:** API Specification 6A, *Specification for Wellhead and Tree Equipment*, 21<sup>st</sup> Edition, November 2018

### Addendum 3

6.2.2: *The first paragraph shall be changed to the following:*

The manufacturer’s written specified requirements for metallic materials for bodies, bonnets, end and outlet connectors, stems, valve bore sealing mechanisms, mandrel hangers, and ring gaskets shall define the following, along with accept/reject criteria:

*Table 17: The table shall be changed to the following:*

Temperature Class	P, S, T, U	K, L
Impact testing of studs, bolts, and screws required	Yes for dia. >2.5" No for dia. ≤2.5"	Yes
Acceptable ASTM bolting standards and grades for studs, bolts, and screws	A193/A193M GR. B7	—
	A320/A320M GR. L7	A320/A320M GR. L7
	A320/A320M GR. L43	A320/A320M GR. L43
	A193/A193M GR. B7M	—
	A320/A320M GR. L7M	A320/A320M GR. L7M
	A453/A453M GR. 660D <sup>b</sup>	A453/A453M GR. 660D <sup>b</sup>
Acceptable ASTM standards and grades for nuts <sup>a</sup>	CRA <sup>c</sup>	CRA <sup>c</sup>
	ASTM A194/A194M	ASTM A194/A194M
	GR. 2H, 2HM, 7, 7L, 7ML, 7M	GR. 2H, 2HM, 7, 7L, 7ML, 7M
FOOTNOTES <sup>a</sup> Impact testing is not required for nuts unless specified by the ASTM referenced standard. <sup>b</sup> Impact testing is not required for A453/A453M GR. 660D. <sup>c</sup> Impact testing per API 20F.		

*10.4.2.4.1: The section shall be renumbered to the as indicated in the red box:*

The requirements of 10.4.1.4 shall apply.

Additionally, the requirements of 10.4.2.4 shall apply to PSL 1, PSL 2, PSL 3, and PSL 4, except as noted in the following.

a) For PSL 1, bodies, bonnets, end and outlet connectors, stems, loose connectors and clamp hub end connectors with 13.8 MPa, 20.7 MPa, and 34.5 MPa (2000 psi, 3000 psi, and 5000 psi) working pressure, sampling shall be in accordance with ISO 2859-1:1999, level II, 4.0 AQL (acceptance quality limit), with the following exception. For DD, EE, FF, and HH material class equipment, each pressure-containing or pressure-controlling part shall be individually hardness tested.

b) For PSL 2, PSL 3, and PSL 4, all parts shall be hardness tested.

NOTE 1 This additional requirement does not apply to PSL 1.

c) For PSL 3 and PSL 4, additionally one hardness test shall be performed on each finished part (body, bonnet, and end connectors) with additional tests on each end connector face. When it is not possible to hardness test the end connector face, the hardness test shall be performed on the nearest accessible surface.

NOTE 2 Where multiple end connector faces are located on the same finished machined surface, a single hardness punch may be used to represent all end connectors.

NOTE 3 This additional requirement does not apply to PSL 1 and PSL 2.

If bodies, end and outlet connectors, and clamp hub ends have different material designations, each part shall be tested.

*10.4.5.4: The following shall be deleted:*

Dimensional inspection shall be performed on ring gaskets and nonintegral metal seals manufactured according to this specification.

Sampling shall be in accordance with the manufacturer's documented requirements.

The manufacturer's documented procedures shall be followed.

Acceptance criteria for ring gaskets shall be in accordance with 14.2.2.1. Nonintegral metal seals shall be in accordance with the manufacturer's documented requirements.

*10.4.5.4.1: The following section shall be added:*

#### **10.4.5.4.1 Nonintegral Metal Seals**

Dimensional inspection shall be performed on nonintegral metal seals manufactured according to this specification.

Sampling shall be in accordance with the manufacturer's documented requirements.

The manufacturer's documented procedures shall be followed.

Acceptance criteria shall be in accordance with the manufacturer's documented requirements.

*10.4.5.4.2: The following section shall be added:*

#### **10.4.5.4.2 Ring Gaskets**

##### **10.4.5.4.2.1 General**

Dimensional inspection shall be performed on ring gaskets manufactured according to this specification.

##### **10.4.5.4.2.2 Inspection of BX 156 and Smaller, BX 169 and BX 170, R, and RX gaskets**

For BX 156 gaskets and smaller, including BX 169, BX 170, R, and RX gaskets, the following shall apply:

Sampling for ring gaskets shall be in accordance with ISO 2859-1:1999, level II, 1.5 AQL.

The manufacturer shall document and maintain a procedure for dimensional inspection.

Acceptance criteria shall be in accordance with 14.2.2.1.

##### **10.4.5.4.2.3 Inspection of BX 157 and Larger Gaskets (Excluding BX 169 and BX 170)**

For BX 157 through BX 303, excluding BX 169 and BX 170 gaskets, the following shall apply:

Sampling for ring gaskets shall be in accordance with ISO 2859-1:1999, level II, 1.0 AQL.

Gaskets shall be in the finished condition and measured in the free state after the gasket has cooled to room temperature. Temperature at the time of inspection shall be included with the inspection records. All measured surfaces shall be clean and ungreased.

NOTE 1 Gaskets may be inspected in the uncoated condition.

Measured dimensions shall conform to the dimensional Table D.12/E.12 (Type BX Ring Gaskets) as applicable.

The manufacturer shall document and maintain a procedure for dimensional inspection.

The process for inspecting the 23° angle shall be documented and validated.

NOTE 2 Validated inspection methods may employ the use of a CMM, a calibrated inspection gauge, or optical device.

The BX gasket shall be inspected according to the following method:

- 1) Measure the ring width (A) and ring height (H) at a minimum of four equidistant locations. See Table D.12/E.12.

- 2) Measure the outer ring diameter ( $\emptyset$  OD Table D.12/E.12) at a minimum of four equidistant diameter locations using a validated inspection procedure. See Table D.12/E.12 for inspection locations.

NOTE 3 Additional inspection locations not shown in Table D.12/E.12 may be used.

- 3) Average the OD dimensions obtained.
- 4) Calculate the ovality of the ring by subtracting the smallest OD dimension from the largest OD dimension obtained in Step 2).
- 5) Determine the percentage difference based on the nominal ring diameter.

NOTE 4 See Table D.12/E.12 for reference to ring width (A) and ring height (H).

#### **10.4.5.4.2.4 Acceptance Criteria**

The difference in width (A) or height (H) between any two measured locations shall not exceed 0.10 mm (0.004 in)

The average OD shall be within the tolerance specified in Table D.12/E.12.

The OD ovality shall not exceed 0.2 % of the nominal ring outside diameter.

NOTE See Table D.12/E.12 for reference to ring width (A) and ring height (H) and outside diameter (OD).

*10.4.5.6: The section shall be changed to the following:*

The manufacturer's documented procedures, including the sampling criteria, shall be followed.

The inspection surfaces of ring gaskets as illustrated in Table 28 shall have a surface finish as specified in Annex D and Annex E.

For nonintegral metal seals, the acceptance criteria for the sealing surface finish shall conform to the manufacturer's documented requirements.

Table 28: The table title and table shall be changed to the following:

**Table 28—Inspection Locations for Ring Gaskets**

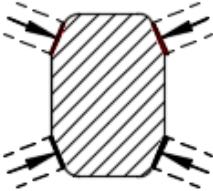
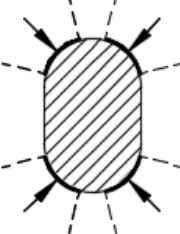
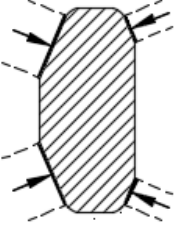
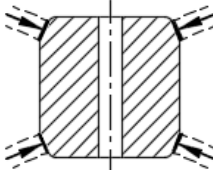
Gasket Type	R (Octagonal)	R (Oval)	RX	BX
Inspection Locations				
<p>NOTE 1 See Annex D.9/E.9, D.10/E.10, and D.12/E.12 for surface finish requirements.</p> <p>NOTE 2 Highlighted dark heavy lines and arrows identify the surfaces subject to visual inspection.</p>				

10.4.5.7: The following section shall be added:

**10.4.5.7 Visual Inspection—Ring Gaskets**

All ring gaskets shall be visually inspected in accordance with the manufacturer’s written specification.

No visible surface defects, as defined in the manufacturer’s written specification, shall be permitted on the inspection surfaces as identified in Table 28.

10.4.5.8: The following section shall be added:

**10.4.5.8 Traceability—Ring Gaskets**

Job-lot and heat traceability shall be required.

Identification shall be maintained on materials and parts to facilitate traceability, as required by documented manufacturer requirements.

Manufacturer-documented traceability requirements shall include provisions for maintenance or replacement of identification marks and identification control records.

13.5: The section shall be changed to the following:

Ring gaskets shall be individually wrapped or boxed for shipment and storage. Ring gaskets with an outside diameter greater than 356 mm (14 in.) should be shipped and stored horizontally (flat).

14.2.3.1.2: The section shall be changed to the following:

When used, coating and plating thicknesses shall be 0.013 mm (0.0005 in.) maximum.

NOTE Coatings and plating may be employed to aid the seal engagement while minimizing galling and to extend shelf life.

*14.2.3.3.1: The section title and content shall be changed to the following:*

#### **14.2.3.3.1 Melting, Casting, Hot Working and Welding**

The following requirements shall apply.

- a) The manufacturer shall specify melting practices that produce material that is homogeneous, free from cracks, banding, piping, and flakes.
- b) Casting practices: Centrifugal casting shall be the only acceptable method of casting ring gaskets.
- c) Hot working practices: Wrought materials shall be hot worked throughout. Ring gaskets may be made from pierced tubing or pipe, rolled rings, or rolled and welded bar or plate.
- d) Welded gaskets: The manufacturer's welding process shall be documented and validated.

*14.2.3.3.2: The section shall be changed to the following:*

All heat-treating of parts shall be performed with equipment meeting the requirements of 6.5.

Heat-treatment operations shall be in accordance with the manufacturer's written specification.

Ring gaskets manufactured from soft iron or carbon or low-alloy steel shall be either normalized or annealed as the last stage of material processing prior to final machining.

Ring gaskets manufactured from 304 stainless steel, 316 stainless steel, nickel alloy UNS N08825, or other CRA materials with an austenitic microstructure shall be solution annealed and quenched to maintain the required microstructure as the last stage of material processing prior to final machining. The applicable ASTM standards or manufacturer's specification shall be followed for heat treatment.

*14.2.3.3.3: The section shall be changed to the following:*

The chemical composition of ring gaskets shall be specified in the manufacturer's material specification (see 6.2).

For stainless steel and CRA materials manufactured by the centrifugal casting method, a process validation shall be performed and documented for a sample heat for each material and each manufacturing process. The analysis shall be performed at the OD and ID of the ring gaskets. The chemical composition at the gasket OD and ID dimension shall conform to the manufacturer's specified tolerances. Revalidation shall be required for any changes in process controls.

Table 39: The table shall be changed to the following:

Marking Requirement	Marking	Location
Date of manufacture	(Month/Year)	Outside diameter of gasket
Traceability to heat and job lot	Traceability Code(s)	Outside diameter of gasket
Manufacturer's name or mark	PMR	Outside diameter of gasket
Ring gasket type and number	Example: "BX 155"	Outside diameter of gasket
Ring gasket manufacturing method [wrought (F), cast (C), or welded (W)]	F	Outside diameter of gasket, following gasket material code, with or without a dash
	C	
	W	
Ring gasket material code:		Outside diameter of gasket, following gasket type and number, with or without a dash  Examples: "R 24-D-W" "RX 39 316 F" "BX 169-825-C"
Soft iron	D	
Carbon or low-alloy steel	S	
304 stainless steel	304	
316 stainless steel	316	
Nickel alloy UNS N08825	825	
Other CRA materials	(UNS number)	

15.2.3: The section shall be changed to the following:

For ring gaskets, the following records shall be maintained:

- chemical analysis/heat number;
- hardness test;
- job lot traceability;
- dimensional inspection.

NOTE For nonintegral metal seals, no records are required.

15.3.3: The section shall be changed to the following:

For BX 157 through BX 303, excluding BX 169 and BX 170, a certificate of conformance stating that equipment meets the requirements of this specification, including the manufacturer's traceability code, shall be furnished to the purchaser.

NOTE For nonintegral metal seals, no records are required to be furnished.

Section B.7: The section shall be changed to the following:

When fire resistance qualification of equipment in this specification is required, the test requirements for qualification shall be specified.

NOTE See API 6FA (for valves) and API 6FB (for OECs) for guidance.

Table D.9: The table shall be changed to the following:

**Table D.9—Type R Ring Gaskets**

Dimensions in millimeters unless noted otherwise; surface roughness in micrometers

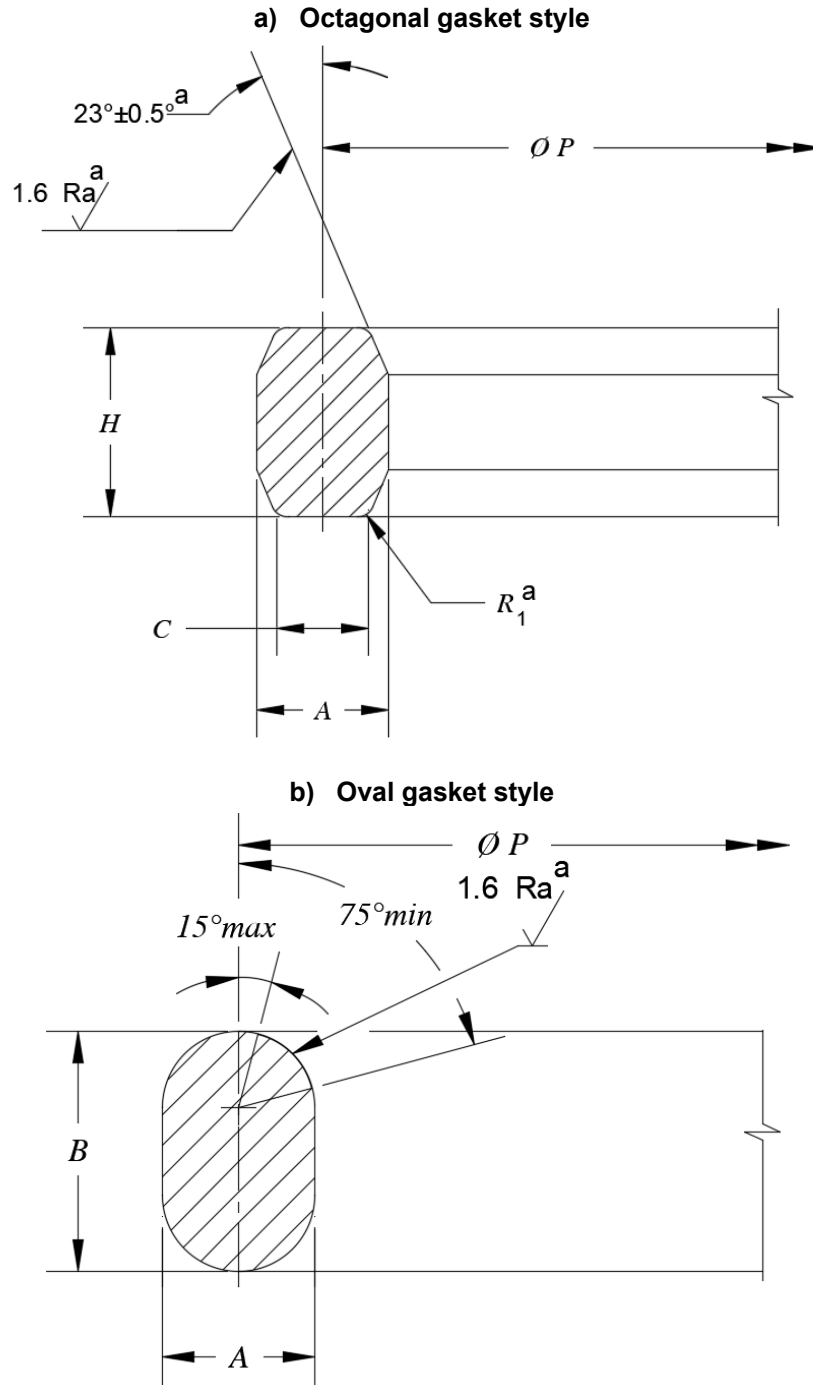

FOOTNOTE

<sup>a</sup> Typical four places.



**Table D.9—Type R Ring Gaskets (continued)**

Dimensions in millimeters unless noted otherwise

Gasket Number	Pitch Diameter	Width of Ring	Height of Oval Ring	Height of Octagonal Ring	Width of Flat on Octagonal Ring	Radius on Octagonal Ring	Distance between Flanges
	<i>P</i>	<i>A</i>	<i>B</i>	<i>H</i>	<i>C</i>	<i>R</i> <sub>1</sub>	<i>S</i>
Tolerance>	± 0.18	± 0.20	± 0.5	± 0.5	± 0.20	± 0.5	(Approx.)
R 23	82.55	11.13	17.5	15.9	7.75	1.5	4.8
R 24	95.25	11.13	17.5	15.9	7.75	1.5	4.8
R 26	101.6	11.13	17.5	15.9	7.75	1.5	4.8
R 27	107.95	11.13	17.5	15.9	7.75	1.5	4.8
R 31	123.83	11.13	17.5	15.9	7.75	1.5	4.8
R 35	136.53	11.13	17.5	15.9	7.75	1.5	4.8
R 37	149.23	11.13	17.5	15.9	7.75	1.5	4.8
R 39	161.93	11.13	17.5	15.9	7.75	1.5	4.8
R 41	180.98	11.13	17.5	15.9	7.75	1.5	4.8
R 44	193.68	11.13	17.5	15.9	7.75	1.5	4.8
R 45	211.15	11.13	17.5	15.9	7.75	1.5	4.8
R 46	211.15	12.70	19.1	17.5	8.66	1.5	4.8
R 49	269.88	11.13	17.5	15.9	7.75	1.5	4.8
R 50	269.88	15.88	22.4	20.6	10.49	1.5	4.1
R 53	323.85	11.13	17.5	15.9	7.75	1.5	4.8
R 54	323.85	15.88	22.4	20.6	10.49	1.5	4.1
R 57	381.00	11.13	17.5	15.9	7.75	1.5	4.8
R 65	469.90	11.13	17.5	15.9	7.75	1.5	4.8
R 66	469.90	15.88	22.4	20.6	10.49	1.5	4.1
R 73	584.20	12.70	19.1	17.5	8.66	1.5	3.3
R 74	584.20	19.05	25.4	23.9	12.32	1.5	4.8

Table D.12: The table shall be changed to the following:

**Table D.12—Type BX Ring Gaskets**

Dimensions in millimeters; surface roughness in micrometers

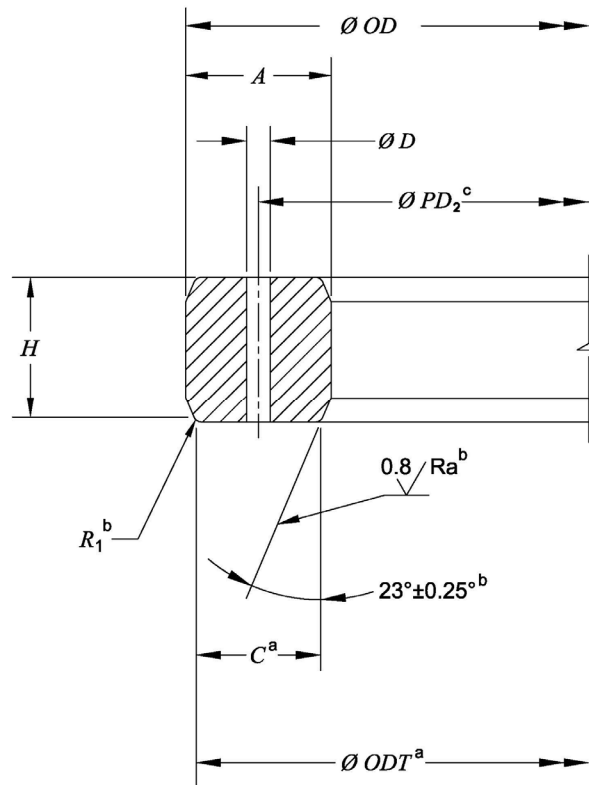

FOOTNOTES

- <sup>a</sup> Typical two places (top and bottom).
- <sup>b</sup> Typical four places (all corners).
- <sup>c</sup> Reference dimension (see Table D.11 for value).

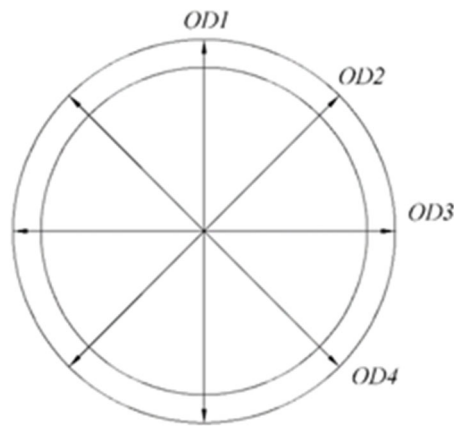

OD MINIMUM INSPECTION LOCATIONS

**Table D.12—Type BX Ring Gaskets (continued)**

Dimensions in millimeters unless noted otherwise

Groove Number	Outside Diameter <sup>a</sup>	Width of Ring <i>A</i>	Height of Ring <i>H</i>	Diameter of Flat <i>ODT</i>	Width of Flat <i>C</i>	Hole Size <i>D</i>	Radius on Ring <i>R<sub>1</sub></i>	
	<i>OD</i>						min.	max.
Tolerance>	+0/-0.15	+0.20/-0	+0.20/-0	± 0.05	+0.15/-0	± 0.5		
BX 151	76.40	9.63	9.63	75.03	8.26	1.6	0.8	1.2
BX 152	84.68	10.24	10.24	83.24	8.79	1.6	0.8	1.2
BX 153	100.94	11.38	11.38	99.31	9.78	1.6	0.9	1.4
BX 154	116.84	12.40	12.40	115.09	10.64	1.6	1.0	1.5
BX 155	147.96	14.22	14.22	145.95	12.22	1.6	1.1	1.7
BX 156	237.92	18.62	18.62	235.28	15.98	3.2	1.5	2.2
BX 157	294.46	20.98	20.98	291.49	18.01	3.2	1.7	2.5
BX 158	352.04	23.14	23.14	348.77	19.86	3.2	1.9	2.8
BX 159	426.72	25.70	25.70	423.09	22.07	3.2	2.1	3.1
BX 160	402.59	13.74	23.83	399.21	10.36	3.2	1.9	2.9
BX 161	491.41	16.21	28.07	487.45	12.24	3.2	2.2	3.4
BX 162	475.49	14.22	14.22	473.48	12.22	1.6	1.1	1.7
BX 163	556.16	17.37	30.10	551.89	13.11	3.2	2.4	3.6
BX 164	570.56	24.59	30.10	566.29	20.32	3.2	2.4	3.6
BX 165	624.71	18.49	32.03	620.19	13.97	3.2	2.6	3.8
BX 166	640.03	26.14	32.03	635.51	21.62	3.2	2.6	3.8
BX 167	759.36	13.11	35.87	754.28	8.03	1.6	2.9	4.3
BX 168	765.25	16.05	35.87	760.17	10.97	1.6	2.9	4.3
BX 169	173.51	12.93	15.85	171.27	10.69	1.6	1.3	1.9
BX 170	218.03	14.22	14.22	216.03	12.22	1.6	1.1	1.7
BX 171	267.44	14.22	14.22	265.43	12.22	1.6	1.1	1.7
BX 172	333.07	14.22	14.22	331.06	12.22	1.6	1.1	1.7
BX 303	852.75	16.97	37.95	847.37	11.61	1.6	3.0	4.6

FOOTNOTE

<sup>a</sup> The requirements of 10.4.5.4.2.3 and 10.4.5.4.2.4 shall apply.

Table E.6: The table shall be changed as indicated in the red box:

Nominal Size of Flange	Radius of Hub <i>R</i>	Bolt Circle <i>BC</i>	Number of Bolts <i>N</i>	Bolt Size and TPI	Bolt Holes <i>BH</i>		Blind Flange		Ring Groove
							C'bore Depth <i>E</i>	Hub Height <i>J<sub>4</sub></i>	
Tolerance	± 0.06	See figure for GDT	(Ref.)	Diameter	Tolerance	max.	min.		
1 <sup>3</sup> / <sub>16</sub>	0.38	8.00	8	1-8	1.12	+0.06/-0.02	—	—	BX 151
2 <sup>1</sup> / <sub>16</sub>	0.38	9.06	8	1 <sup>1</sup> / <sub>8</sub> -8	1.25	+0.06/-0.02	—	—	BX 152
2 <sup>9</sup> / <sub>16</sub>	0.38	10.31	8	1 <sup>1</sup> / <sub>4</sub> -8	1.38	+0.06/-0.02	—	—	BX 153
3 <sup>1</sup> / <sub>16</sub>	0.38	11.31	8	1 <sup>3</sup> / <sub>8</sub> -8	1.50	+0.06/-0.02	—	—	BX 154
4 <sup>1</sup> / <sub>16</sub>	0.38	14.06	8	1 <sup>3</sup> / <sub>4</sub> -8	1.88	+0.09/-0.02	—	—	BX 155
7 <sup>1</sup> / <sub>16</sub>	0.62	21.81	16	2-8	2.12	+0.09/-0.02	0.438	0.31	BX 156
9	1.00	27.00	16	2 <sup>1</sup> / <sub>2</sub> -8	2.62	+0.09/-0.02	0.500	0.25	BX 157
11	1.00	29.50	16	2 <sup>3</sup> / <sub>4</sub> -8	2.88	+0.09/-0.02	0.562	0.50	BX 158
13 <sup>5</sup> / <sub>8</sub>	1.00	40.00	20	3-8	3.12	+0.12/-0.02	0.625	0.56	BX 159

Table E.9: The table shall be changed to the following:

**Table E.9—Type R Ring Gaskets**

Dimensions in inches; surface roughness in microinches

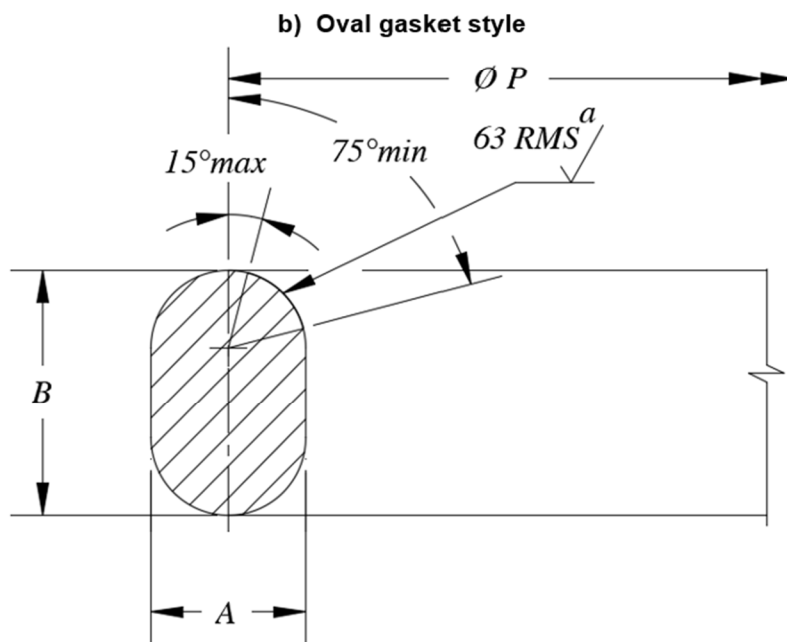
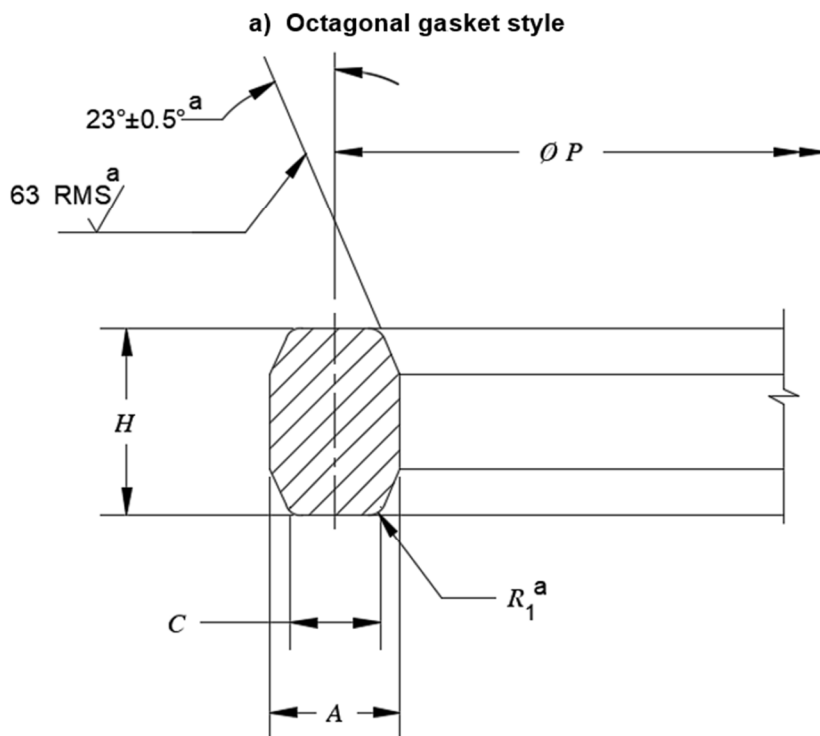

FOOTNOTE

<sup>a</sup> Typical four places.

**Table E.9—Type R Ring Gaskets (continued)**

Dimensions in inches

Gasket Number	Pitch Diameter	Width of Ring	Height of Oval Ring	Height of Octagonal Ring	Width of Flat on Octagonal Ring	Radius on Octagonal Ring	Distance between Flanges
	<i>P</i>	<i>A</i>	<i>B</i>	<i>H</i>	<i>C</i>	<i>R</i> <sub>1</sub>	<i>S</i>
Tolerance>	± 0.007	± 0.008	± 0.02	± 0.02	± 0.008	± 0.02	(Approx.)
R 23	3.250	0.438	0.69	0.63	0.305	0.06	0.19
R 24	3.750	0.438	0.69	0.63	0.305	0.06	0.19
R 26	4.000	0.438	0.69	0.63	0.305	0.06	0.19
R 27	4.250	0.438	0.69	0.63	0.305	0.06	0.19
R 31	4.875	0.438	0.69	0.63	0.305	0.06	0.19
R 35	5.375	0.438	0.69	0.63	0.305	0.06	0.19
R 37	5.875	0.438	0.69	0.63	0.305	0.06	0.19
R 39	6.375	0.438	0.69	0.63	0.305	0.06	0.19
R 41	7.125	0.438	0.69	0.63	0.305	0.06	0.19
R 44	7.625	0.438	0.69	0.63	0.305	0.06	0.19
R 45	8.313	0.438	0.69	0.63	0.305	0.06	0.19
R 46	8.313	0.500	0.75	0.69	0.341	0.06	0.19
R 49	10.625	0.438	0.69	0.63	0.305	0.06	0.19
R 50	10.625	0.625	0.88	0.81	0.413	0.06	0.16
R 53	12.750	0.438	0.69	0.63	0.305	0.06	0.19
R 54	12.750	0.625	0.88	0.81	0.413	0.06	0.16
R 57	15.000	0.438	0.69	0.63	0.305	0.06	0.19
R 65	18.500	0.438	0.69	0.63	0.305	0.06	0.19
R 66	18.500	0.625	0.88	0.81	0.413	0.06	0.16
R 73	23.000	0.500	0.75	0.69	0.341	0.06	0.13
R 74	23.000	0.750	1.00	0.94	0.485	0.06	0.19

Table E.12: The table shall be changed to the following:

**Table E.12—Type BX Ring Gaskets**

Dimensions in inches; surface roughness in microinches

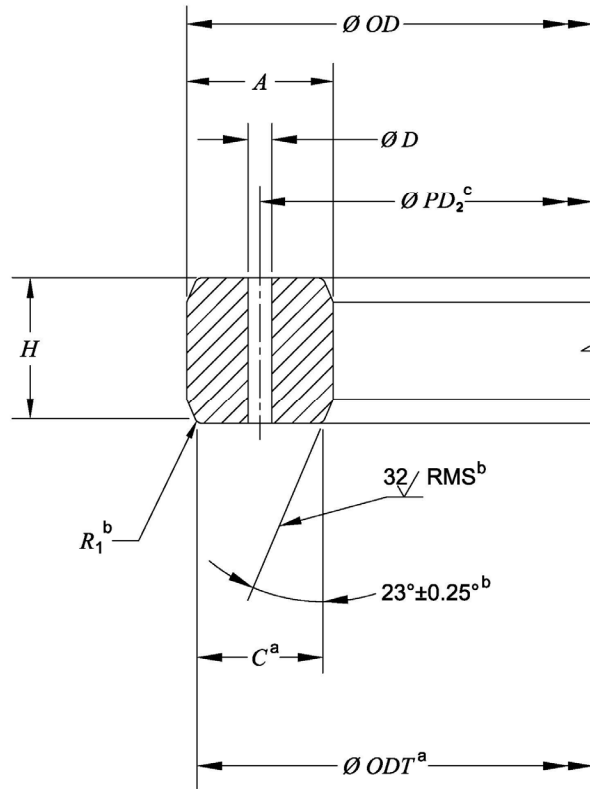

FOOTNOTES

- a Typical two places (top and bottom).
- b Typical four places (all corners).
- c Reference dimension (see Table E.11 for value).

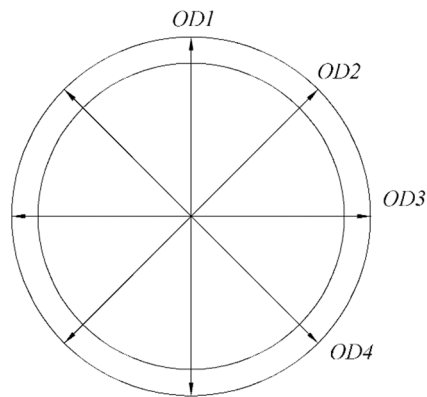

*OD MINIMUM INSPECTION LOCATIONS*

**Table E.12—Type BX Ring Gaskets (continued)**

Dimensions in inches

Groove Number	Outside Diameter <sup>a</sup>	Width of Ring	Height of Ring	Diameter of Flat	Width of Flat	Hole Size	Radius on Ring	
	<i>OD</i>	<i>A</i>	<i>H</i>	<i>ODT</i>	<i>C</i>	<i>D</i>	<i>R<sub>1</sub></i>	
Tolerance>	+0 -0.006	+0.008 -0	+0.008 -0	± 0.002	+0.006 -0	± 0.02	min.	max.
BX 151	3.008	0.379	0.379	2.954	0.325	0.06	0.03	0.05
BX 152	3.334	0.403	0.403	3.277	0.346	0.06	0.03	0.05
BX 153	3.974	0.448	0.448	3.910	0.385	0.06	0.04	0.05
BX 154	4.600	0.488	0.488	4.531	0.419	0.06	0.04	0.06
BX 155	5.825	0.560	0.560	5.746	0.481	0.06	0.04	0.07
BX 156	9.367	0.733	0.733	9.263	0.629	0.12	0.06	0.09
BX 157	11.593	0.826	0.826	11.476	0.709	0.12	0.07	0.10
BX 158	13.860	0.911	0.911	13.731	0.782	0.12	0.07	0.11
BX 159	16.800	1.012	1.012	16.657	0.869	0.12	0.08	0.12
BX 160	15.850	0.541	0.938	15.717	0.408	0.12	0.08	0.11
BX 161	19.347	0.638	1.105	19.191	0.482	0.12	0.09	0.13
BX 162	18.720	0.560	0.560	18.641	0.481	0.06	0.04	0.07
BX 163	21.896	0.684	1.185	21.728	0.516	0.12	0.09	0.14
BX 164	22.463	0.968	1.185	22.295	0.800	0.12	0.09	0.14
BX 165	24.595	0.728	1.261	24.417	0.550	0.12	0.10	0.15
BX 166	25.198	1.029	1.261	25.020	0.851	0.12	0.10	0.15
BX 167	29.896	0.516	1.412	29.696	0.316	0.06	0.11	0.17
BX 168	30.128	0.632	1.412	29.928	0.432	0.06	0.11	0.17
BX 169	6.831	0.509	0.624	6.743	0.421	0.06	0.05	0.07
BX 170	8.584	0.560	0.560	8.505	0.481	0.06	0.04	0.07
BX 171	10.529	0.560	0.560	10.450	0.481	0.06	0.04	0.07
BX 172	13.113	0.560	0.560	13.034	0.481	0.06	0.04	0.07
BX 303	33.573	0.668	1.494	33.361	0.457	0.06	0.12	0.18

FOOTNOTE

<sup>a</sup> The requirements of 10.4.5.4.2.3 and 10.4.5.4.2.4 shall apply.