

An Insight Into API RP 577 Welding Inspection & Metallurgy

Frank T Furillo

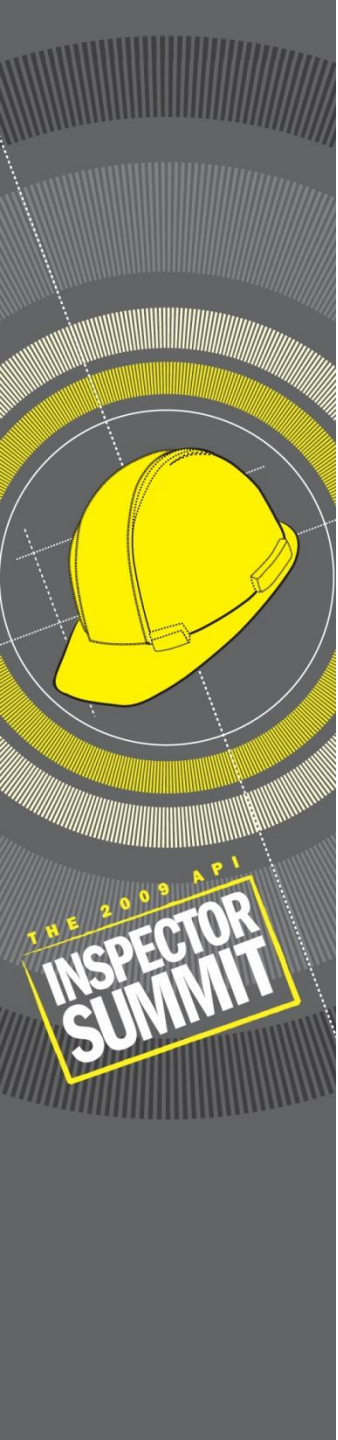

Frank T Furillo

Frank Furillo, Consultant.

Risk-Based Inspection and Inspection

- 28 Years Experience with Exxon and Mobil
- Past Chairman API Subcommittee on Inspection

Current activities

- Risk-Based Inspection/Equipment Strategies
- PMI Risk Assessment
- Inspection Program Assessment
- API Master Editor

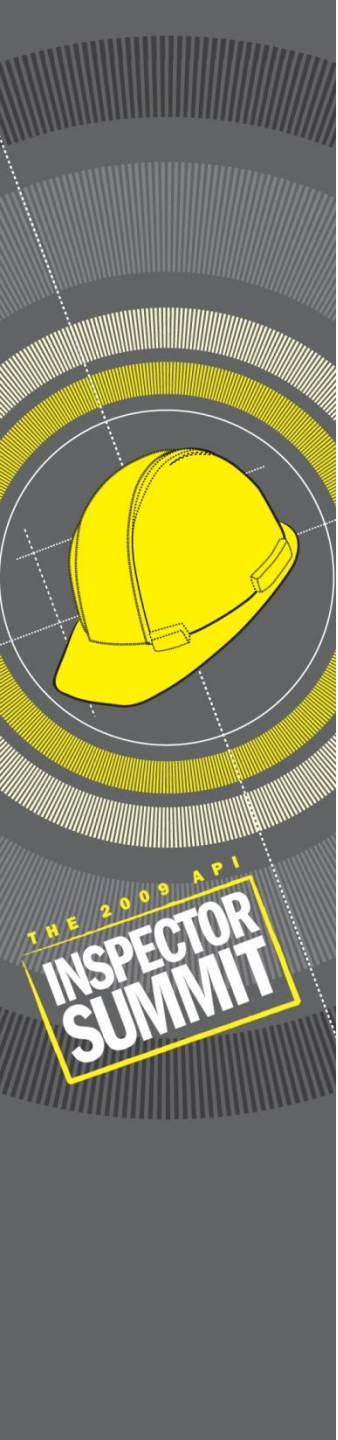

Setting the Tone

■ Purpose of Presentation

- Review of Essential Elements of First Edition
- Direction & Improvements Planned For Second Edition.
- Learn of Issues to be Addressed

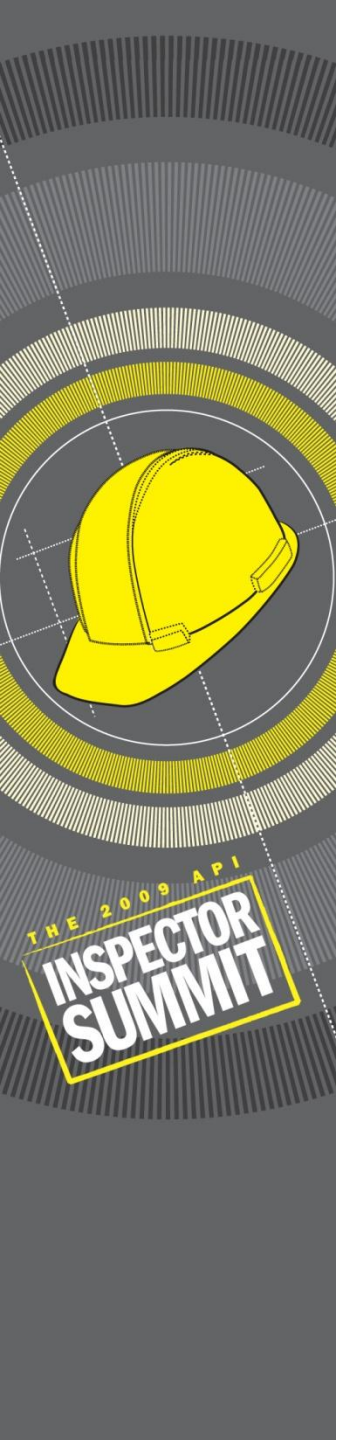

Status Of Document.

First Edition was published October 2004 and is now due for revision.

A task group is currently preparing the second edition for ballot.

- API 577 questions appear on the 510/570 & 653 Exams.
- It is also the basis for a supplementary certification exam.

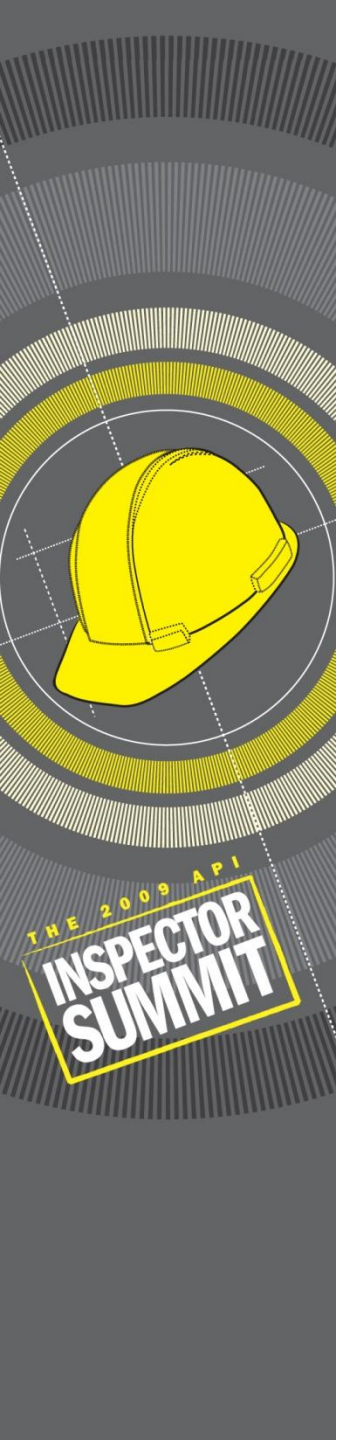

Contents of API RP 577

1. Scope
2. References
3. Definitions
4. Welding Inspection
5. Welding Processes
6. Welding Procedure
7. Welding Materials
8. Welder Qualification
9. Non Destructive Examination
10. Metallurgy
11. Refinery & Petrochemical Plant Welding Issues

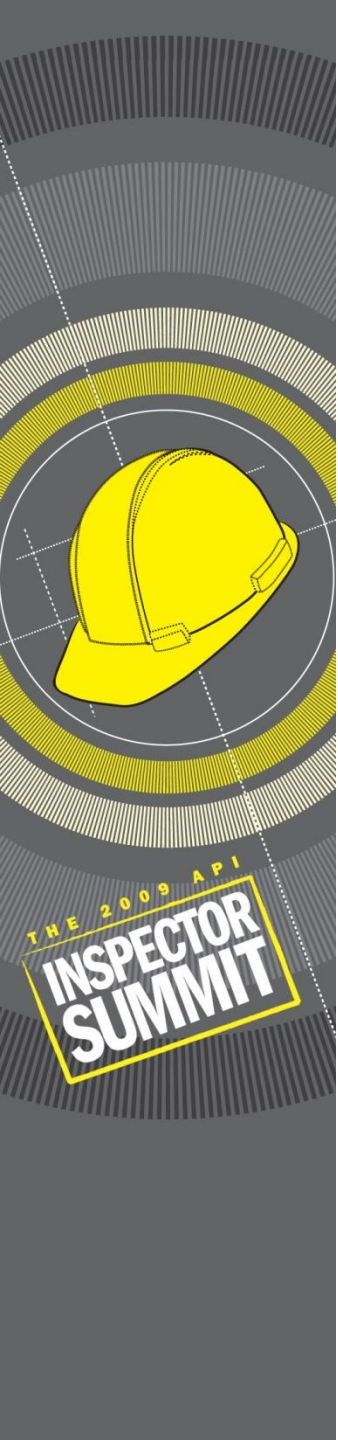

1.0 Scope.

- **This RP covers the many welding processes and their effects on the metallurgy of the components being joined.**
- **It includes the most common welding processes used for refinery and chemical plant equipment and piping.**
- **The RP covers the areas an API Authorized Inspector needs to know when welding is being performed on equipment governed by API 510, 570, or 653.**
- **This RP is not intended to replace the Training & and experience requirements of AWS Certified Welding Inspectors.**



3.0 Definitions.

Major Topics Include:

- **Weld Joint Nomenclature**
- **Types of Weld**
- **Types Of Weld Joints**
- **Weld NDE / Q/A Nomenclature**
- **Welding Equipment Nomenclature**

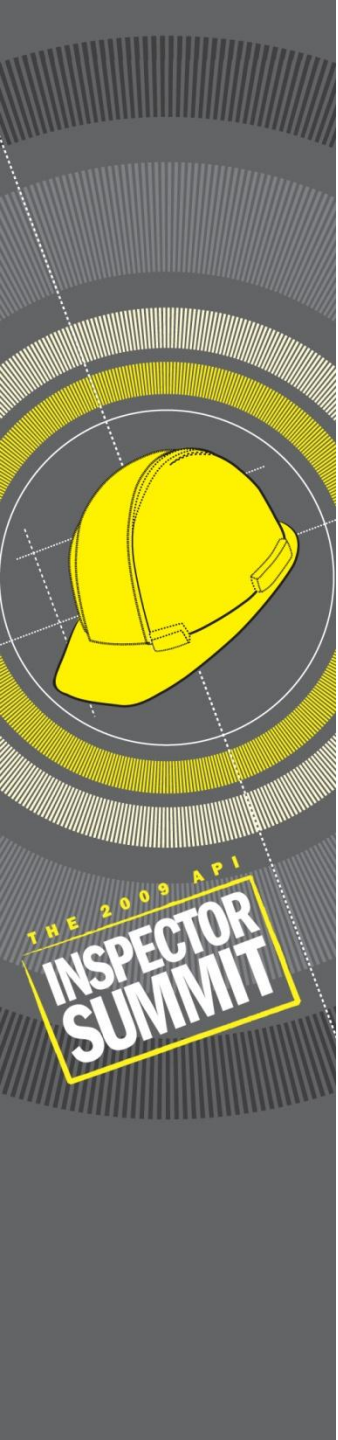

4.0 Welding Inspection.

Each Section outlines Q/A items needed to be assessed by the Inspector along with potential actions to be taken for:

- a) Tasks Prior to Welding**
- b) Tasks During Welding**
- c) Tasks Upon Completion of Welding**

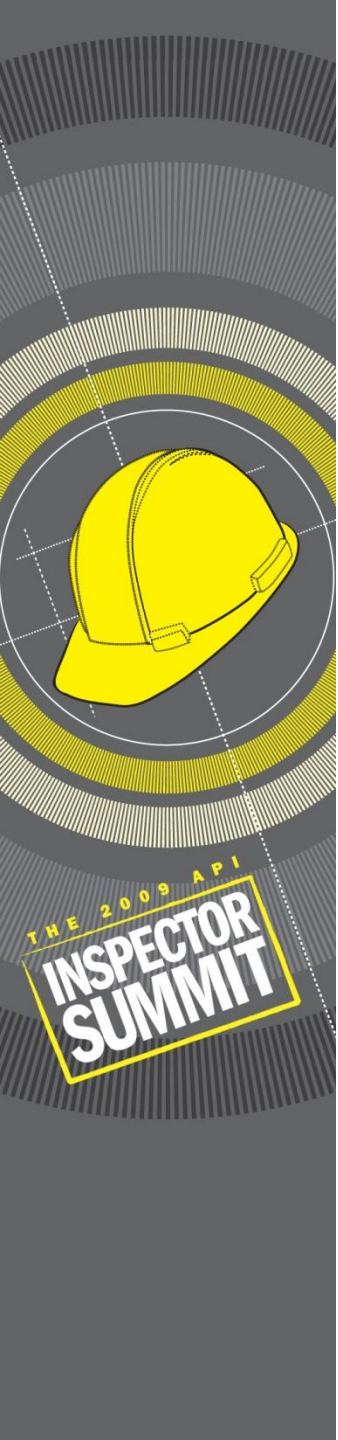

4.2 Tasks Prior to Welding

Covers tasks in the planning and weld preparation stage, and includes tasks for review of:

- a) Drawings/Codes/Standards**
- b) Weldment requirements**
- c) Welding procedures/qualification records**
- d) NDE information**
- e) Welding equipment and instruments**
- f) Heat treatment and pressure testing**
- g) Materials**
- h) Weld preparation**
- i) Preheat**
- j) Welding consumables**

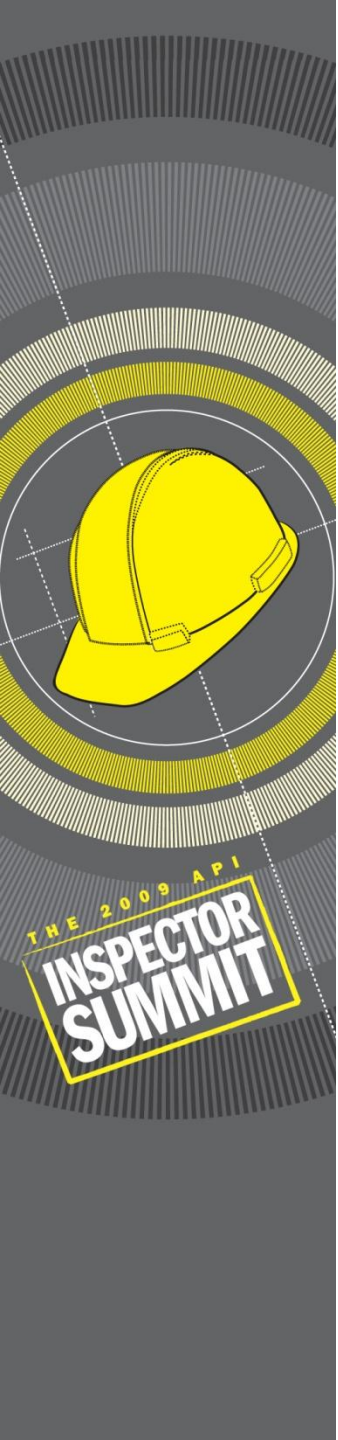

4.2 Tasks Prior to Welding (cont.)

For example, for “Procedures and Qualification Records”,

Q/A items to assess are:

- WPS’s are properly qualified and meet applicable codes, standards and specifications
- PQR’s are properly performed and support the WPS’s
- WPQ meets requirements for WPS

Potential inspector actions are:

- Obtain acceptable WPS’s and PQR’s
- Qualify WPS’s where required and witness qualification effort
- Qualify/requalify welders where required and witness a percentage of welder qualifications



4.2 Tasks Prior to Welding (cont.)

Section 4.2.1.1 Draws Attention To Data Contained In Appendix A & D,, such as:

- **Welding Symbols And Weld Sizes**
- **Weld Joint Designs**
- **Welding Consumables**

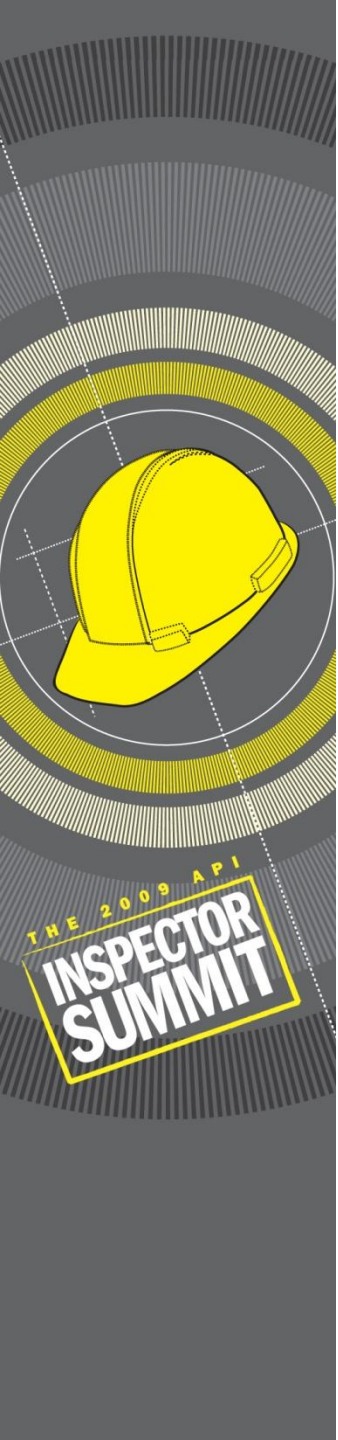

Weld Joint Types & Applicable Welds.

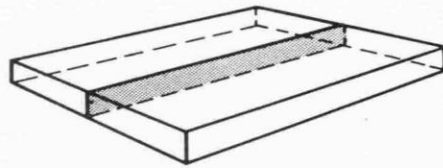

(A) BUTT JOINT

APPLICABLE WELDS

BEVEL-GROOVE	U-GROOVE
FLARE-BEVEL-GROOVE	V-GROOVE
FLARE-V-GROOVE	EDGE-FLANGE
J-GROOVE	BRAZE
SQUARE-GROOVE	

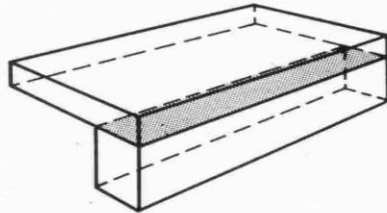

(B) CORNER JOINT

APPLICABLE WELDS

FILLET	V-GROOVE
BEVEL-GROOVE	PLUG
FLARE-BEVEL-GROOVE	SLOT
FLARE-V-GROOVE	SPOT
J-GROOVE	SEAM
SQUARE-GROOVE	PROJECTION
U-GROOVE	BRAZE

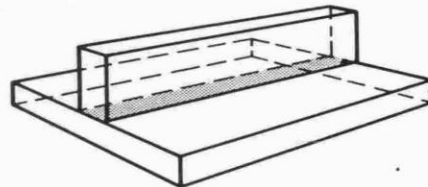

(C) T-JOINT

APPLICABLE WELDS

FILLET	SLOT
BEVEL-GROOVE	SPOT
FLARE-BEVEL-GROOVE	SEAM
J-GROOVE	PROJECTION
SQUARE-GROOVE	BRAZE
PLUG	

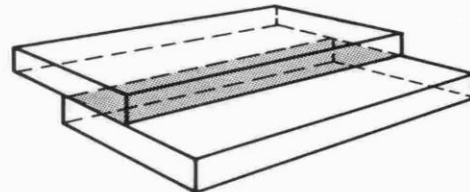

(D) LAP JOINT

APPLICABLE WELDS

FILLET	SLOT
BEVEL-GROOVE	SPOT
FLARE-BEVEL-GROOVE	SEAM
J-GROOVE	PROJECTION
PLUG	BRAZE

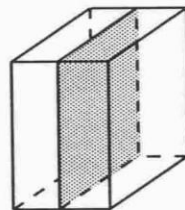

(E) EDGE JOINT

APPLICABLE WELDS

BEVEL-GROOVE	U-GROOVE
FLARE-BEVEL-GROOVE	V-GROOVE
FLARE-V-GROOVE	EDGE
J-GROOVE	SEAM
SQUARE-GROOVE	

Symbols For Various Welds

GROOVE							
SQUARE	SCARF	V	BEVEL	U	J	FLARE-V	FLARE-BEVEL

FILLET	PLUG OR SLOT	STUD	SPOT OR PROJECTION	SEAM	BACK OR BACKING	SURFACING	FLANGE	
							EDGE	CORNER

NOTE: THE REFERENCE LINE IS SHOWN DASHED FOR ILLUSTRATIVE PURPOSES.

Figure 1 — Weld Symbols



Supplementary Symbols







WELD ALL AROUND	FIELD WELD	MELT THROUGH	CONSUMABLE INSERT (SQUARE)	BACKING OR SPACER (RECTANGLE)	CONTOUR		
					FLUSH OR FLAT	CONVEX	CONCAVE
							

Figure 3 — Supplementary Symbols

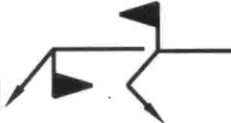

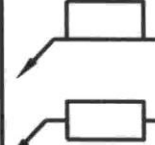
Standard Weld Symbols

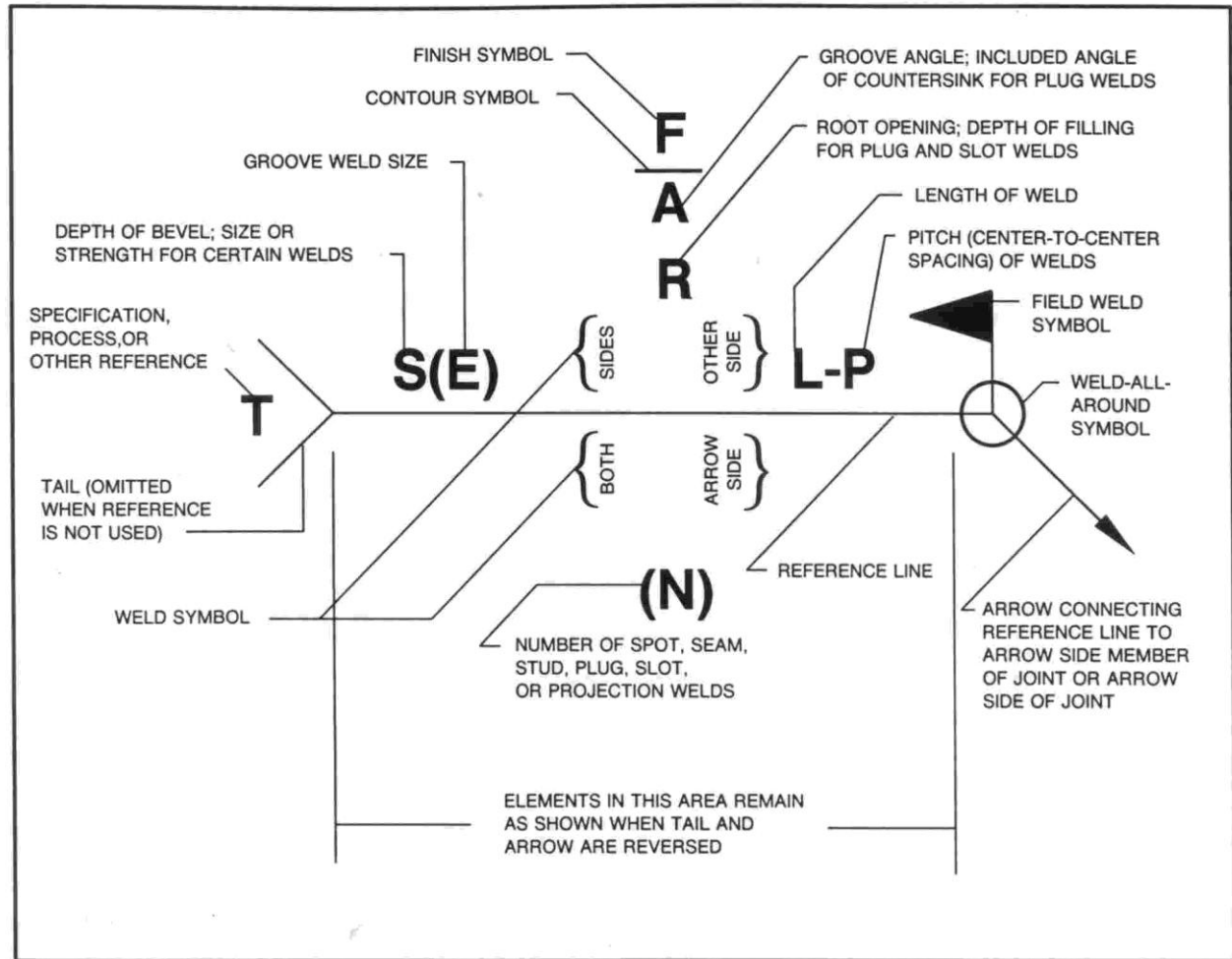
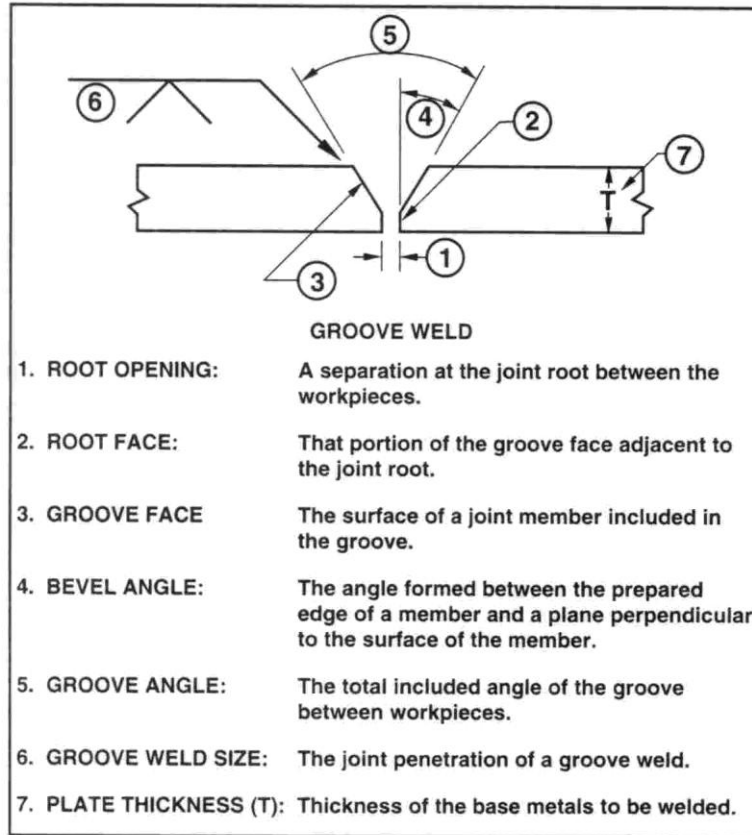

Figure 2 — Standard Location of Elements of a Welding Symbol

Groove Weld Nomenclature



THE 2009 API
**INSPECTOR
SUMMIT**



4.3 Tasks During Welding

Covers inspection tasks during welding, and includes tasks for review of:

- a) Quality assurance
- b) Welding parameters and techniques
- c) Weldment examination

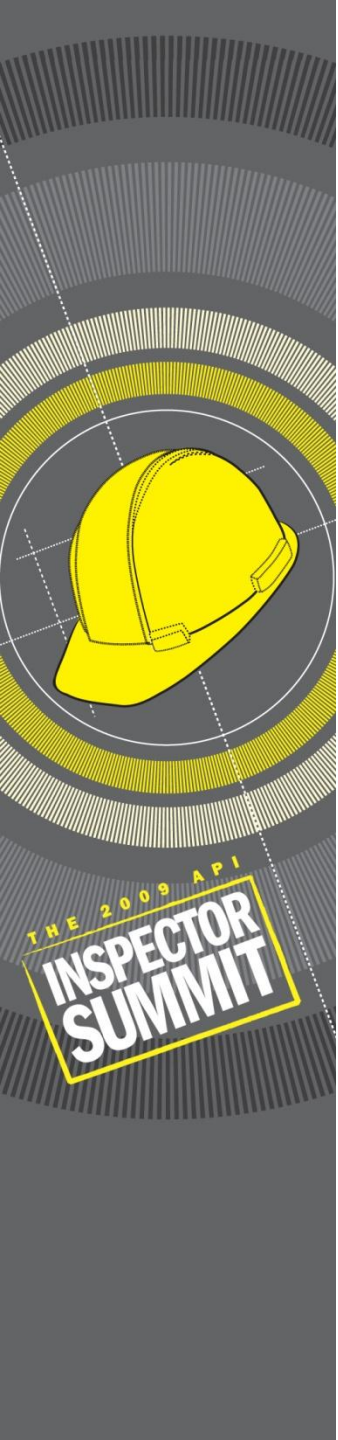

4.3 Tasks During Welding (cont.)

For example, for “Weldment Examinations”,

Q/A items to assess are:

- Tack welds are acceptable quality
- Weld root has adequate penetration and quality
- Acceptable cleaning between weld passes and any back-gouged (b-g) surfaces
- Additional NDE between weld passes and on b-g'd surfaces
- In-process rework and defect removal accomplished
- In-process ferrite measurement performed (if necessary)
- Size of final weld reinforcement and fillet weld meets specifications/drawings.

Potential inspector actions are:

- Reject unacceptable workmanship



4.4 Tasks Upon Completion of Welding

Covers final tasks upon completion of welding, and includes tasks for review of:

- a) Appearance and finish
- b) NDE
- c) Post-weld heat treatment
- d) Pressure testing
- e) Documentation audit

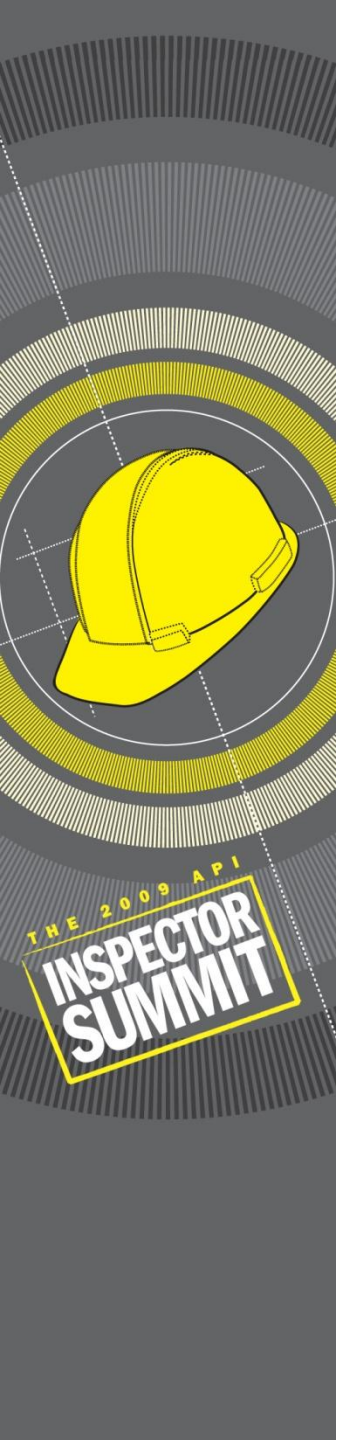

4.4 Tasks Upon Completion of Welding (cont.)

For example, for “Documentation Audit”,

Q/A items to assess are:

- All verifications in quality plan properly executed
- Inspection reports complete, accepted and signed by responsible parties.
- Inspection reports, NDE examiners interpretations and findings are accurate

Potential inspector actions are:

- Require additional inspection verifications to address finding deficiencies
- Report missing/unacceptable examinations
- Correct discrepancies in examination records

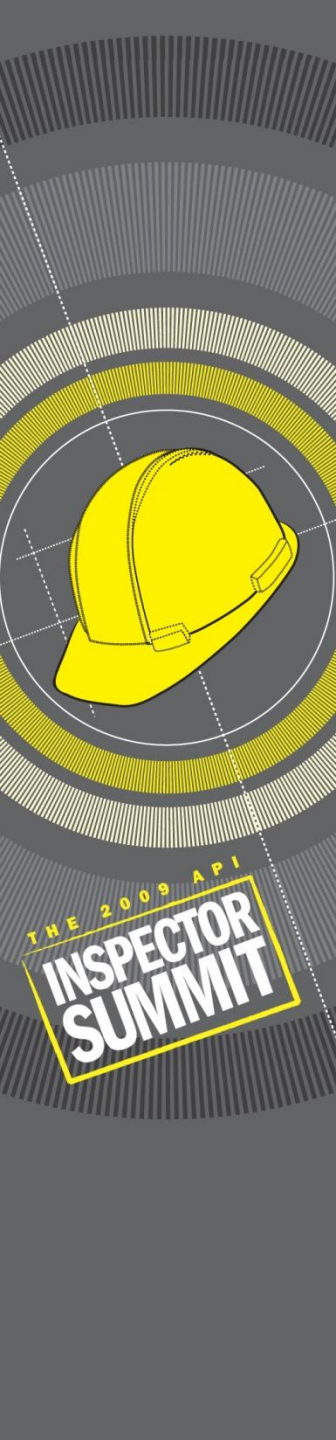

5.0 Welding Processes.

This Section describes the basic arc welding processes such as:

- Shielded Metal Arc welding (SMAW)
- Gas Tungsten Arc Welding (GTAW)
- Gas Metal Arc Welding (GMAW)
- Flux Cored Arc Welding (FCAW)
- Submerged Arc Welding (SAW)
- Stud Welding (SW)

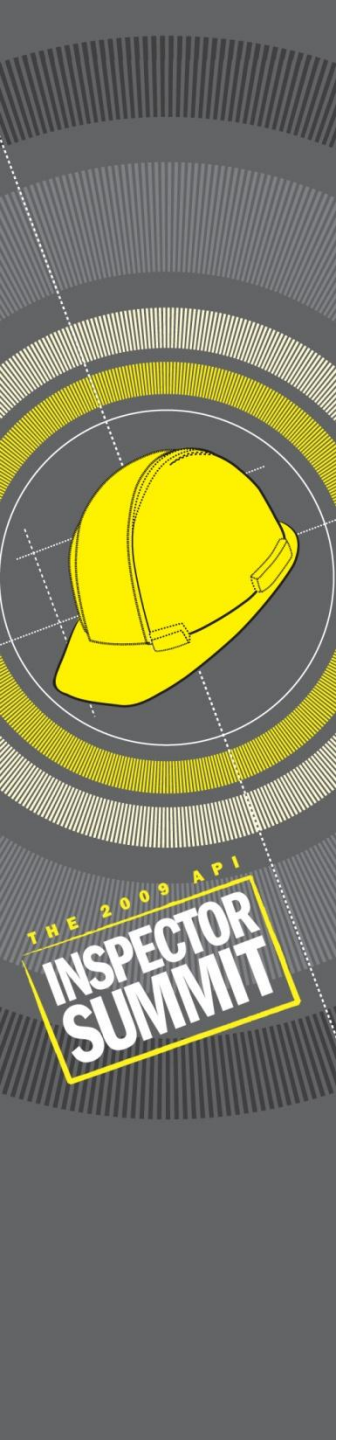

5.2 SMAW Welding Process (example)

Each Section on welding processes includes a general description of the welding process, the welding equipment/components required, and the advantages and limitations of each welding process.

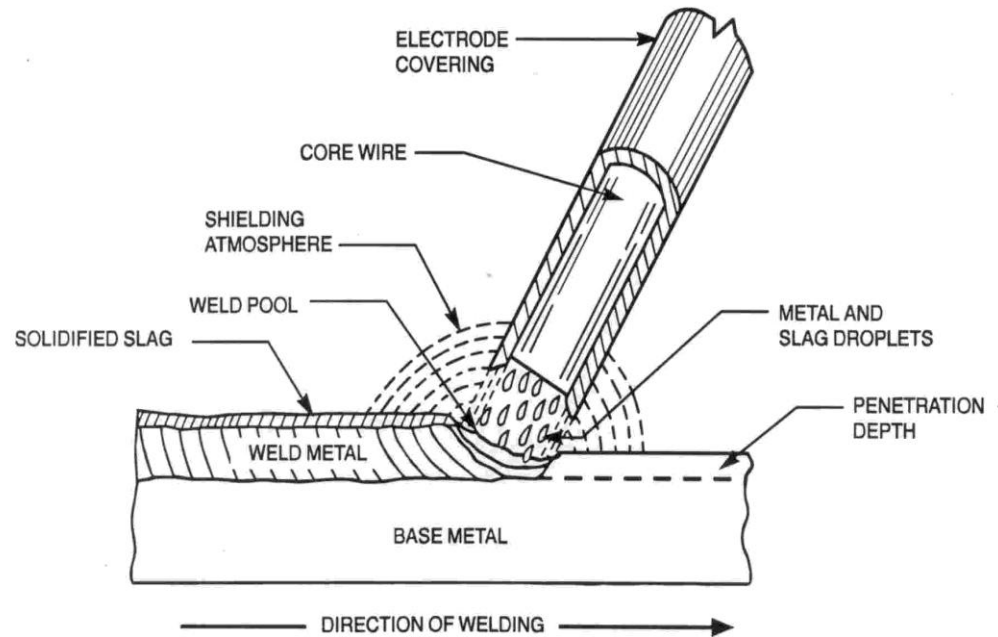

Figure S-6—Schematic View of Shielded Metal Arc Welding

6.0 Welding Procedure

This section covers:

- Welding Specification Procedure (WPS)
 - Types of Essential Variables
 - Other Requirements (i.e. toughness, preheat, hardness, etc.)
- Procedure Qualification Record (PQR)
- How to review a WPS and PQR
 - Items to be included on WPS
 - Items to be included on PQR

This Section is a very relevant section for inspectors. Verification and validation of the correct content of procedures is critical.



7.0 Welding Materials.

This Section discusses the following:

- P-Number Assignment to Base Metals
- F-Number Assignment to Filler Metals
- AWS Classification of Filler Metals
- A-Number for steel and steel alloy Filler Metals
- Filler Metal Selection
- Consumable Storage and Handling

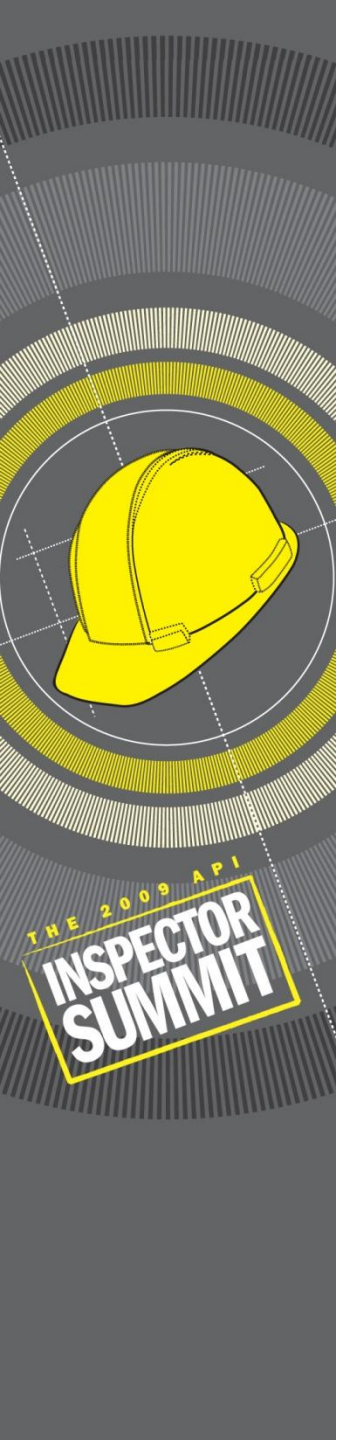

7.0 Welding Materials (cont.)

<u>Base Metal</u>	<u>Welding</u>	<u>Brazing</u>
Steel and steel alloys	P-No. 1 through P-No. 11 incl. P-No. 5A, 5B, and 5C	P-No. 101 through P-No. 103
Aluminum and aluminum-base alloys	P-No. 21 through P-No. 25	P-No. 104 and P-No. 105
Copper and copper-base alloys	P-No. 31 through P-No. 35	P-No. 107 and P-No. 108
Nickel and nickel-base alloys	P-No. 41 through P-No. 47	P-No. 110 through P-No. 112
Titanium and titanium-base alloys	P-No. 51 through P-No. 53	P-No. 115
Zirconium and zirconium-base alloys	P-No. 61 through P-No. 62	P-No. 117

8.0 Welder Qualification.

This Section discusses Welder Qualifications, and includes:

- Welder Performance Qualification (WPQ)
- How to review a WPQ
 - Prior to welding
 - Verifying the qualification range

This is the second most important task of an inspector. It is widely covered in ASME Section IX, but often there are additional rules or waivers to be found in design codes.

(This section will be enhanced in the 2nd Edition with guidance on handling when welders fail tests.)

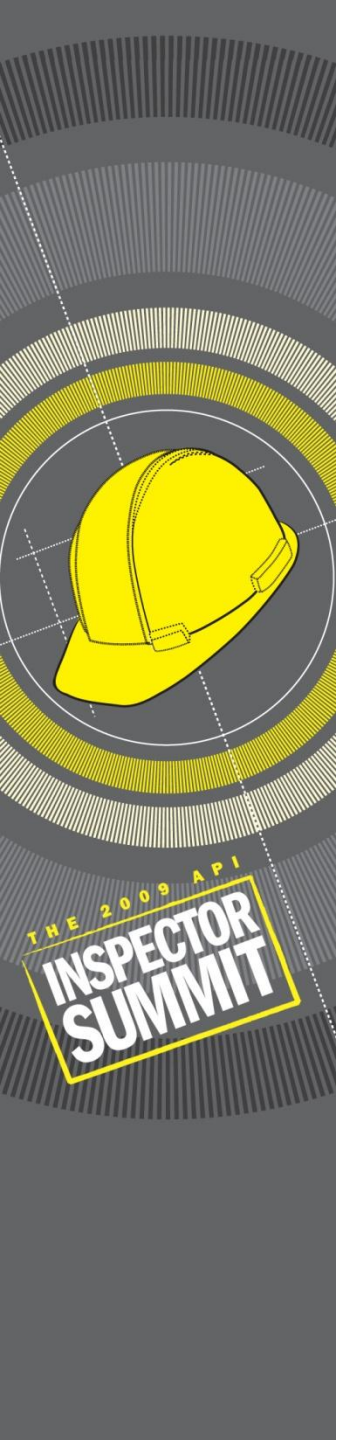

9.0 Non-Destructive Examination.

A topic all on its own much discussed in presentations at this summit. This Section is the largest part of the document, and discusses:

- Types and Locations of Discontinuities
- Capability of Inspection Methods based on weld joint type, Inspection Method vs. Discontinuity Type, and Welding Process vs. Discontinuity Type
- Materials Identification
- Inspection Methods, Techniques and Tools for VT, MT, ACFM, PT, RT, UT, Hardness Testing, Pressure Testing, and Data Recording

(The discussion on Hardness and Pressure Testing will be enhanced in the 2nd Edition.)

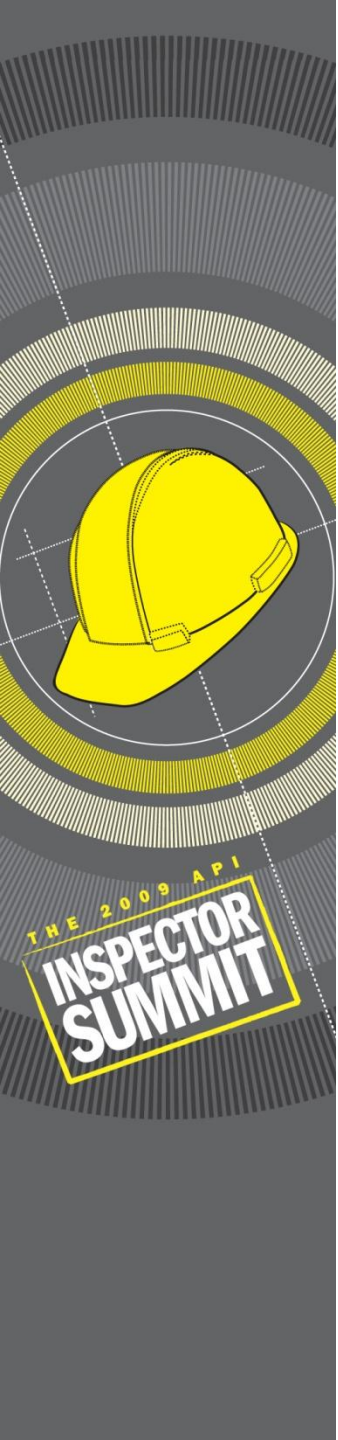

9.0 Non-Destructive Examination (cont.)

Table 1
Common types of discontinuities

Type of Discontinuity	Section	Location*	Remarks
1 Porosity	2.3	WM	Porosity is also commonly found in the heat-affected zone if base metal is a casting.
(a) Uniformly scattered	2.3.1		
(b) Cluster	2.3.2		
(c) Linear	2.3.3		
(d) Piping	2.3.4		
2 Inclusions	2.4	WM	
(a) Slag	2.4.1		
(b) Tungsten	2.4.2		
3 Incomplete fusion	2.5	WM, BM/WM	Also between passes.
4 Incomplete joint penetration	2.6	BM	Weld root.
5 Undercut	2.7	BM/WM	Adjacent to weld toe or weld root in base metal.
6 Underfill	2.8	WM	Weld face or root surface.
7 Overlap	2.9	BM/WM	Weld toe or root surface.
8 Laminations	2.10	BM	Base metal, generally near midthickness of section.
9 Delamination	2.11	BM	Base metal, generally near midthickness of section.
10 Seam and laps	2.12		Base metal surface almost always aligned with rolling direction.
11 Lamellar tears	2.13	BM	Base metal, near HAZ.
12 Cracks (includes hot cracks and cold cracks described in text)	2.14		
(a) Longitudinal	2.14.1 2.14.2, 2.14.3	WM, HAZ	Weld metal or base metal adjacent to weld interface.
(b) Transverse	2.14.2, 2.14.4	WM, HAZ, BM	Weld metal (may propagate into HAZ and base metal).
(c) Crater	2.14.5	WM	Weld metal at point where arc is terminated.
(d) Throat	2.14.6	WM	Parallel to weld axis.
(e) Toe	2.14.7	BM/WM	
(f) Root	2.14.8	WM	Root surface.
(g) Underbead and heat-affected zone	2.14.9	BM/WM	
13 Insufficient throat	2.15	WM	Weld face.
14 Convexity or weld reinforcement	2.16	WM	Weld face.
15 Insufficient leg	2.17	WM	Fillet weld.

*WM—weld metal
BM—base metal
HAZ—heat affected zone
BM/WM—weld interface



9.0 Non-Destructive Examination (cont.)

Table 4
Applicable inspection methods—four weld joint types

Joints	Inspection methods					
	RT	UT	PT	MT	VT	ET
Butt	A	A	A	A	A	A
Corner	O	A	A	A	A	O
T	O	A	A	A	A	O
Lap	O	O	A	A	A	O

Legends:

RT—Radiographic testing

UT—Ultrasonic testing

PT—Penetrant testing, including both DPT (dye penetrant testing) and FPT (fluorescent penetrant testing)

MT—Magnetic particle testing

VT—Visual testing

ET—Eddy Current testing

A—Applicable Method

O—Marginal applicability depending on other factors such as material thickness, discontinuity size, orientation and location

9.0 Non-Destructive Examination (cont.)

Table 3
Applicable inspection methods vs. discontinuities

Discontinuities	Applicable inspection methods					
	RT	UT	PT	MT	VT	ET
Porosity	A	O	A ^a	O ^b	A ^a	O
Slag inclusions	A	A	U	O ^b	U	O
Incomplete fusion	O	A	U	O ^b	U	O
Incomplete penetration	A	A	U	O	U	O
Undercut	A	O	O	O	A	O
Overlap	U	O	A	A	O	O
Cracks	O	A	A ^a	A ^b	A ^a	A
Laminations	U	A	A ^{a,c}	A ^{b,c}	A ^{a,c}	U

Notes:

- a. Surface
- b. Surface and slightly subsurface
- c. Weld preparation or edge of base metal

Legends:

- RT—Radiographic testing
- UT—Ultrasonic testing
- PT—Penetrant testing, including both DPT (dye penetrant testing) and FPT (fluorescent penetrant testing)
- MT—Magnetic particle testing
- VT—Visual testing
- ET—Eddy current testing
- A—Applicable Method
- O—Marginal applicability depending on other factors such as material thickness, discontinuity size, orientation and location

9.10 Hardness Testing.

Currently this section outlines more about laboratory hardness testing than field testing which is of greater interest to inspectors.

(This will be addressed with enhanced guidance on field hardness testing in the 2nd Edition.)

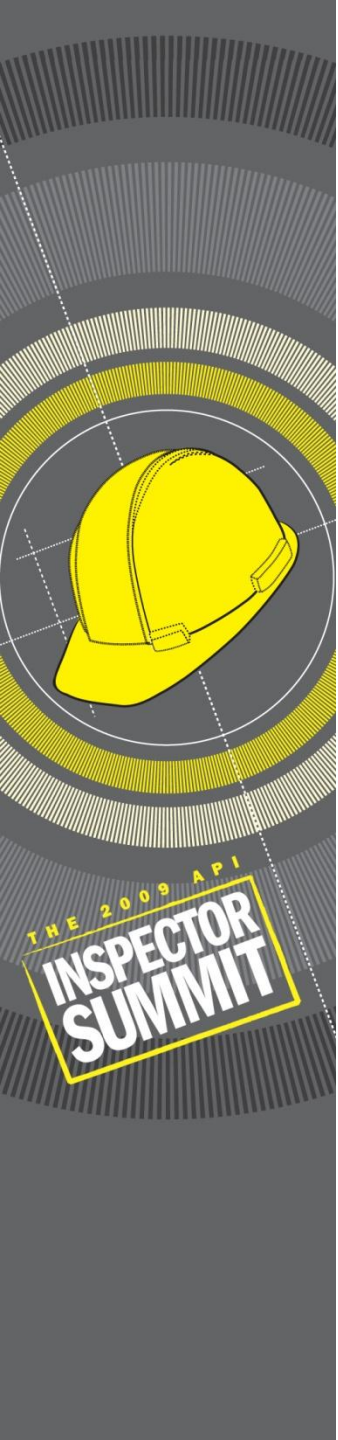

10.0 Metallurgy.

- **Structure of Castings, Wrought Materials, and Welding Metallurgy**
- **Physical Properties**
- **Mechanical Properties**
- **Preheating**
- **Post-Weld Heat Treatment**
- **Hardening**
- **Material Test Reports**
- **Weldability of Steels**
- **Weldability of High Alloys**
- **Nickel Alloys**

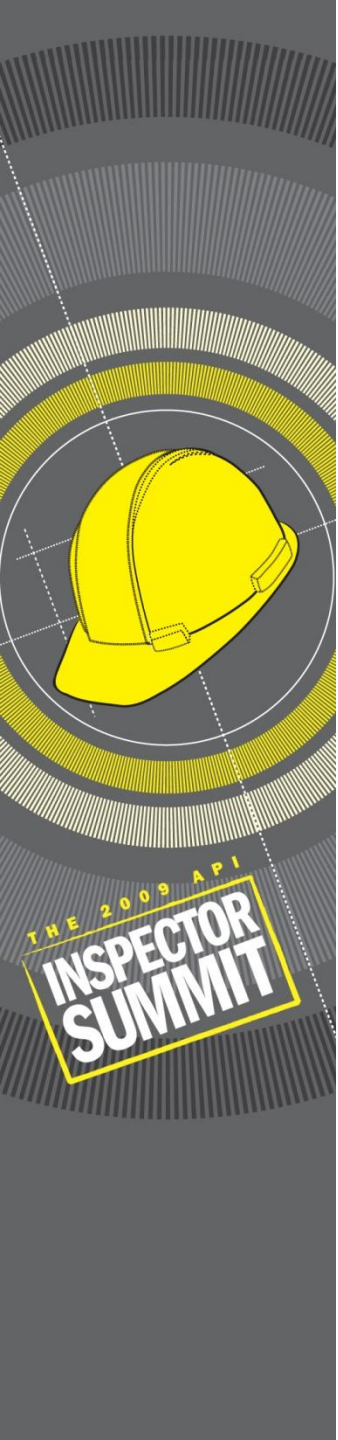

11.0 Plant Welding Issues

This Section covers:

- **Hot Tapping and In-Service welding**
 - **Electrode Considerations**
 - **Product Flow Rates**
 - **Other Considerations**
 - **Inspection**
- **Lack of Fusion with GMAW-S**

Appendices

There are Appendices covering Welding Symbols, Improperly Made Production Welds, Welding Procedure Review, Filler Metal Selection and Example Report of RT Results



Questions ???

- a) Problems with the 1st Edition ???
- b) Comments for improvements/additions in the 2nd Edition ???
- c) Volunteers to work on the 2nd Edition ???

